



Most Widely Accepted and Trusted

ICC-ES Report

ESR-1347

ICC-ES | (800) 423-6587 | (562) 699-0543 | www.icc-es.org

Reissued 05/2017
This report is subject to renewal 05/2019.

DIVISION: 06 00 00—WOOD, PLASTICS AND COMPOSITES
SECTION: 06 05 23—WOOD, PLASTIC, AND COMPOSITE FASTENINGS

REPORT HOLDER:

R.H. TAMLYN & SONS, LP

**13623 PIKE ROAD
STAFFORD, TEXAS 77477**

EVALUATION SUBJECT:

TAMLYN AND SONS WOOD STRUCTURAL CONNECTORS



Look for the trusted marks of Conformity!

"2014 Recipient of Prestigious Western States Seismic Policy Council (WSSPC) Award in Excellence"



A Subsidiary of  INTERNATIONAL CODE COUNCIL™

ICC-ES Evaluation Reports are not to be construed as representing aesthetics or any other attributes not specifically addressed, nor are they to be construed as an endorsement of the subject of the report or a recommendation for its use. There is no warranty by ICC Evaluation Service, LLC, express or implied, as to any finding or other matter in this report, or as to any product covered by the report.



ICC-ES Evaluation Report

ESR-1347

Reissued May 2017

This report is subject to renewal May 2019.

www.icc-es.org | (800) 423-6587 | (562) 699-0543

A Subsidiary of the International Code Council®

DIVISION: 06 00 00—WOOD, PLASTICS AND COMPOSITES
Section: 06 05 23—Wood, Plastic, and Composite Fastenings

REPORT HOLDER:

R. H. TAMLYN AND SONS, LP
13623 PIKE ROAD
STAFFORD, TEXAS 77477-5103
(281) 499-9604
www.tamlyn.com
info@tamlyn.com

EVALUATION SUBJECT:

TAMLYN AND SONS WOOD STRUCTURAL CONNECTORS

1.0 EVALUATION SCOPE

Compliance with the following codes:

- 2012 and 2009 *International Building Code*® (IBC)
- 2012 and 2009 *International Residential Code*® (IRC)
- 2013 *Abu Dhabi International Building Code* (ADIBC)[†]

[†]The ADIBC is based on the 2009 IBC. 2009 IBC code sections referenced in this report are the same sections in the ADIBC.

Property evaluated:

Structural

2.0 USES

R. H. Tamlyn and Sons, LP, wood structural connectors are used as wood framing connectors.

3.0 DESCRIPTION

3.1 Single Joist Hanger (SJK) Series and Double Joist Hanger (ALUS) Series:

The SJK series hangers are U-shaped hangers formed from No. 20 gage [0.036 inch (0.9 mm)] design thickness galvanized steel; the ALUS series hangers are U-shaped hangers formed from No. 18 gage [0.048 inch (1.2 mm)] galvanized steel. The SJK and ALUS series hangers are attached to the joist member with nails. Nailing schedules, dimensions and allowable loads must be in accordance with Table 1. See Figure 1 and Table 1 of this report for further details and information.

3.2 Special Joist Hanger (ALUS & AU) Series:

The ALUS & AU series hangers are U-shaped hangers formed from No. 18 gage [0.048 inch (1.2 mm)] galvanized steel. The ALUS & AU hanger series are attached to the joist member with nails. Nailing schedules, dimensions and allowable loads must be in accordance with Table 2. See

Figure 2 and Table 2 of this report for further details and information.

3.3 Rafter Tie (RT and HT) Series:

The RT series and HT series anchors are fabricated in various configurations and are designed to connect joists or rafters to wall plates and/or studs. The RT and HT series are formed from No. 18 gage [0.048 inch (1.2 mm)] galvanized steel. Nailing schedules, dimensions and allowable loads must be in accordance with Table 3. See Figure 3 and Table 3 of this report for further details and information.

3.4 Truss Hanger (TH and DTH) Series:

The TH and DTH series truss hangers are designed for use with wood joists, trusses or headers. The TH and DTH series are formed from No. 18 gage [0.048 inch (1.2 mm)] galvanized steel. Nailing schedules, dimensions and allowable loads must be in accordance with Table 4. See Figure 4 and Table 4 of this report for further details and information.

3.5 Flat Wall Brace (WB and WBT) Series:

The WB wall brace is a flat, 1¹/₄-inch-wide (31.8 mm) strap of No. 16 gage [0.060 inch (1.5 mm)] galvanized steel furnished in lengths ranging from 9 feet 3 inches (2819.4 mm) to 15 feet 6 inches (4724.4 mm). The braces are installed at approximately a 45-degree or 60-degree angle in a manner similar to that for wood let-in braces. The WBT wall brace is a T-section brace formed from No. 22 gage [0.030 inch (0.7mm)] galvanized steel, with a 2-inch-wide (50.8 mm) flange and a 7/16-inch-deep (11.1 mm) web section. The WBT series come in lengths of either 9 feet 6 inches (2895.6mm) or 11 feet 4 inches (3453.4 mm). The WBT braces are also installed at approximately a 45-degree or 60-degree angle in a manner similar to that for wood let-in braces. The WB and WBT series wall braces are alternatives to the code-prescribed bracing method, as noted in IBC Section 2308.9.3(1) and IRC Section R602.10.3(1). Nail schedules and dimensions must be in accordance with Table 5. See Figure 5 and Table 5 of this report for further details and information.

3.6 Hurricane Strap (SS, MSS and HSS) Series:

The SS, MSS and HSS series straps are designed to act as tension ties between two butting wood members. The straps are formed from Nos. 16, 18 and 20 gage [0.060 inch (1.5 mm), 0.048 inch (1.2 mm) and 0.036 inch (0.9 mm)] galvanized steel and are punched to receive 10d common nails. Nailing schedules, dimensions and allowable loads must be in accordance with Table 6. See Figure 6 and Table 6 of this report for further details and information.

3.7 Nail Plate (TNP) Series:

ICC-ES Evaluation Reports are not to be construed as representing aesthetics or any other attributes not specifically addressed, nor are they to be construed as an endorsement of the subject of the report or a recommendation for its use. There is no warranty by ICC Evaluation Service, LLC, express or implied, as to any finding or other matter in this report, or as to any product covered by the report.

The TNP nail plates are designed to provide positive connections at wall intersections and ridge ties when the top plates are cut. The TNP series are also used for truss repairs or construction and splice applications on wood-to-wood splices. The TNP nail plates are formed from No. 20 gage [0.036 inch (0.9 mm)] galvanized steel. Nailing schedules, dimensions and allowable loads must be in accordance with Table 7. See Figure 7 and Table 7 of this report for further details and information.

3.8 CS Series Coil Strap:

The CS Series coil strap is a flat, 1 1/4-inch-wide strap designed to act as a tension tie to connect wood studs. The straps are formed from Nos. 16, 18, 20 and 22 gage [0.0600 inch (1.5 mm), 0.048 inch (1.2 mm), 0.036 inch (0.9 mm) and 0.030 inch (0.7 mm)] galvanized steel and are punched to receive 8d or 10d common nails. Nailing schedules, dimensions and allowable loads must be in accordance with Table 8. See Figure 8 and Table 8 for further details and information.

3.9 TLCE4 Post Cap:

The TLCE4 post caps are designed to connect wood post and beam members. The TLCE 4 post caps are formed from 20 gage [0.036 inch (0.9 mm)] galvanized steel and are punched to receive 16d common nails. Nailing schedules, dimensions and allowable loads must be in accordance with Table 9. See Figure 9 and Table 9 for further details and information.

3.10 TRSPT6-2 Stud Plate Tie:

The TRSPT6-2 stud plate ties are designed to connect wood studs to bottom single plates and top double plates. The TRSPT6-2 stud plate ties are formed from 18 gage [0.048 inch (1.2 mm)] galvanized steel and are punched to receive 10d common nails. Nailing schedules, dimensions and allowable loads must be in accordance with Table 10. See Figure 10 and Table 10 for further details and information.

3.11 Materials:

3.11.1 Steel: The R.H. Tamlyn and Sons connectors described in this report are manufactured from galvanized steel sheet conforming to ASTM A653 CS, G90. These connectors are produced using a die made to form each connector. With the exception of the SS, MSS and HSS series straps described in Section 3.6, the galvanized sheet steel from which the connectors are manufactured has a minimum yield strength of 33,000 psi (227 MPa) and a minimum tensile strength of 45,000 psi (310 Mpa). Hurricane Strap (SS, MSS and HSS) series straps are manufactured from galvanized sheet steel having minimum yield strengths of either 33,000 or 48,000 psi (227 or 331 Mpa) and minimum tensile strengths of either 45,000 or 58,000 psi (310 and 400 Mpa), respectively. Connectors described in this report are cold-formed and galvanized to Coating Designation G90 in accordance with ASTM A653.

The galvanized steel used in the connectors described in this report has the following minimum base-metal thicknesses:

NOMINAL GAGE NO.	MINIMUM BASE-METAL THICKNESS (inch)
16	0.0600
18	0.0480
20	0.0360
22	0.0300

For SI: 1 inch = 25.4 mm.

3.11.2 Wood: Wood members with which the connectors are used must be nominal-dimension lumber or approved structural composite lumber, and are limited to lumber that has not been treated with fire-retardant chemicals or preservatives. Wood members must have a moisture content not exceeding 19 percent, unless the connection has been designed with the appropriate wet service factor, C_M , as noted in Section 10.3.3 of the NDS.

Beams or headers supporting joists must have the following minimum widths based on nail sizes attaching the joist hangers to the beam or header:

NAIL SIZE	MINIMUM SIZE OF BEAM, OR HEADER WIDTH
8d and 10d	1.5 inches (38 mm)
16d	3.5 inches (89 mm)

For SI: 1 inch = 25.4 mm.

3.11.3 Fasteners: Nails are common steel wire nails of the penny weight noted in the tables of this evaluation report. The nails must comply with ASTM F1667 and must have the following minimum dimensions and bending yield strengths, F_{yb} :

COMMON NAIL PENNYWEIGHT	NAIL DIAMETER x LENGTH (inches)	F_{yb} (psi)
8d	0.131 x 1 1/2	100,000
8d	0.131 x 2 1/2	100,000
10d	0.148 x 1 1/2	90,000
10d	0.148 x 3	90,000
16d	0.162 x 3.5	90,000

For SI: 1 inch = 25.4 mm; 1 psi = 6.895 kPa.

3.11.4 Use with Treated Wood: Use of the connectors and specified fasteners with preservative-treated or fire-retardant-treated wood is outside the scope of this report. R. H. Tamlyn and Sons, LP, or the manufacturers of the chemical treatment must be consulted for recommendations on minimum corrosion-resistant protection for the steel connectors and fasteners used with specific wood treatments.

3.12 Design:

3.12.1 General: Allowable load capacities in this evaluation report are based on allowable stress design. Tabulated allowable loads are for normal duration and short durations, based on load duration factors, C_D , in accordance with Section 10.3.2 of the NDS. No further increases in allowable loads are permitted.

Tabulated allowable loads are for connections in wood seasoned to a moisture content of 19 percent or less, used under continuously dry interior conditions, and where sustained temperatures are 100°F (37.8°C) or less.

When connectors are installed, in wood, having a moisture content greater than 19 percent, or where wet service is expected, the allowable loads in this evaluation report must be adjusted by the wet service factor, C_M , specified in Section 10.3.3 of the NDS.

When connectors are installed in wood that will experience sustained exposure to temperatures exceeding 100°F (37.7°C), the allowable loads in this evaluation report must be adjusted by the temperature factor, C_t , specified in Section 10.3.4 of the NDS.

Group action factor, C_g , has been accounted for, in accordance with Section 10.3.6 of the NDS, in the tabulated loads, where applicable.

Connected wood members must be checked for load-carrying capacity at the connection in accordance with Section 10.1.2 of the NDS.

3.12.2 Design of TNP-Series Nail Plates: Tamlyn and Sons nail plate connectors used to connect wood joists and rafters must be designed not to exceed the allowable load capacities shown in Table 7 of this report. This evaluation report establishes nail plate allowable design values only. The allowable design values are applicable for metal plate connected wood members when connections are made with identical plates on opposite sides of the joint. The design, fabrication and installation of all framing members for which nail plates are used must be in accordance with the requirements of the appropriate design specification as referenced in the applicable code, engineering drawings, and ANSI/TP1, National Design Standard for Metal Plate Connected Wood Truss Construction.

4.0 INSTALLATION

Installation of the connectors must be in accordance with this evaluation report and the manufacturer’s published installation instructions.

5.0 CONDITIONS OF USE

The R. H. Tamlyn and Sons, LP, wood structural connectors described in this report comply with, or are suitable alternatives to what is specified in, those codes listed in Section 1.0 of this report, subject to the following conditions:

- 5.1 The connectors must be manufactured, identified and installed in accordance with this report and the manufacturer’s instructions.
- 5.2 Design loads must be less than the allowable loads indicated in Tables 1 through 10.
- 5.3 Connected lumber must comply with Section 3.9 of this report.
- 5.4 Adjustment factors noted in Section 3.9 of this report and the applicable codes must be considered where applicable.

- 5.5 Fasteners must comply with Section 3.8.3 of this report.
- 5.6 Calculations showing compliance with this report must be submitted to the code official. The calculations must be prepared by a registered design professional where required by the statutes of the jurisdiction in which the project is to be constructed.
- 5.7 Use of connectors with treated lumber, such as preservative-treated and fire-retardant-treated lumber, is outside the scope of this report. Refer to Section 3.8.4 of this report for details.
- 5.8 Products are manufactured by R. H. Tamlyn and Sons, LP, in Stafford, Texas, under a quality control program with annual inspections by ICC-ES.

6.0 EVIDENCE SUBMITTED

- 6.1 Data in accordance with ICC-ES Acceptance Criteria for Joist Hangers and Similar Devices (AC13) Appendix A, dated June 2015.
- 6.2 Report of tests in accordance with ASTM E72 for Flat Wall Brace (WB and WBT) series.
- 6.3 Engineering calculations for nail plate connectors.

7.0 IDENTIFICATION

Each connector described in this report is identified by the product model number and the evaluation report number (ESR-1347).

For field identification, each package of R. H. Tamlyn and Sons wood structural connectors described in this evaluation report is identified by a stamp bearing the manufacturer’s name (TAMLYN) and/or trademark and the product name or type, the manufacturer’s installation instructions and the evaluation report number (ESR-1347).

TABLE 1—SINGLE AND DOUBLE JOIST HANGERS SJQ AND ALUS SERIES ALLOWABLE LOADS (POUNDS)⁵

MODEL	DIMENSIONS (INCHES)			STEEL GAGE NO.	NAIL SCHEDULE ¹		ALLOWABLE LOADS – SYP ² (LBS)			
	H	W	B		Joist	Header	Uplift ³ 160%	Gravity ⁴ 100%	Gravity ⁴ 115%	Gravity ⁴ 125%
SJQ24	3 ¹ / ₈	1 ⁵ / ₈	1 ¹ / ₂	20	2	4	394	492	566	615
SJQ26	4 ³ / ₄	1 ⁵ / ₈	1 ¹ / ₂	20	4	6	787	738	849	923
SJQ28	7	1 ⁵ / ₈	1 ¹ / ₂	20	6	8	1181	984	1132	1230
SJQ210	7 ⁷ / ₈	1 ⁵ / ₈	1 ¹ / ₂	20	6	10	1181	1230	1415	1538
ALUS26-2	5 ¹ / ₂	3 ¹ / ₈	2	18	4	8	794	992	1100	1100
ALUS28-2	7 ¹ / ₄	3 ¹ / ₈	2	18	6	12	1190	1488	1711	1860
ALUS210-2	8 ¹ / ₂	3 ¹ / ₈	2	18	8	14	1587	1736	1996	2170

For SI: 1 inch = 25.4 mm, 1 lbf = 4.5 N.

¹Nails are 10d by 1¹/₂ inch joist hanger nails complying with Section 3.8.3.

²Allowable loads are for hangers nailed into wood or structural composite lumber having an effective specific gravity of 0.55 (such as Southern Pine) or greater.

³Allowable uplift loads have been adjusted by a load duration factor C_D, of 1.6 (160%), corresponding to the typical duration of wind and earthquake loads. No further increases in allowable loads are permitted.

⁴Allowable gravity (bearing) loads have been adjusted by load duration factors, C_D, of 1.0 (100%), 1.15 (115%), and 1.25 (125%), corresponding to the typical durations of occupancy live loads, snow loads and construction loads, respectively. No further increases in allowable loads are permitted.

⁵Tabulated loads are without a 33% steel stress increase. Application of steel stress increase is not permitted.

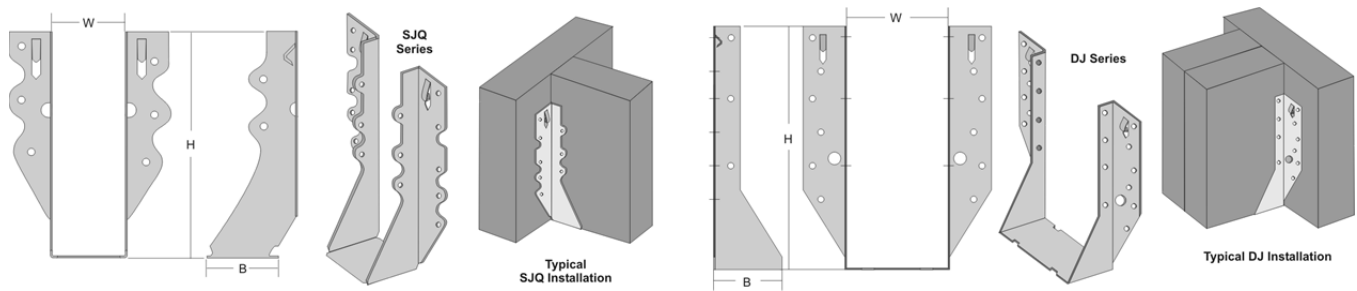

FIGURE 1—SJQ AND ALUS SERIES

TABLE 2—TRIPLE & QUAD JOIST HANGER ALUS & AU SERIES ALLOWABLE LOADS (POUNDS)⁵

MODEL	DIMENSIONS (INCHES)			STEEL GAGE NO.	NAIL SCHEDULE ¹		ALLOWABLE LOADS – SYP ² (LBS)			
	H	W	B		Joist	Header	Uplift ³ 160%	Gravity ⁴ 100%	Gravity ⁴ 115%	Gravity ⁴ 125%
ALUS46	7	3 1/2	2	18	6	12	1190	1488	1711	1860
ALUS410	8 3/8	3 1/2	2	18	8	14	1587	1736	1996	2170
ALUS210-3	7 3/4	4 1/2	2	18	8	14	1587	1736	1996	2000
AU410	10	6	3 1/2	18	4	6	794	744	856	930

For SI: 1 inch = 25.4 mm, 1 lbf = 4.5 N.

¹Nails are 10d by 1 1/2 inch joist hanger nails complying with Section 3.8.3.

²Allowable loads are for hangers nailed into wood or structural composite lumber having an effective specific gravity of 0.55 (such as Southern Pine) or greater.

³Allowable uplift loads have been adjusted by a load duration factor C_D, of 1.6 (160%), corresponding to the typical duration of wind and earthquake loads. No further increases in allowable loads are permitted.

⁴Allowable gravity (bearing) loads have been adjusted by load duration factors, C_D, of 1.0 (100%), 1.15 (115%), and 1.25 (125%), corresponding to the typical durations of occupancy live loads, snow loads and construction loads, respectively. No further increases in allowable loads are permitted.

⁵Tabulated loads are without a 33% steel stress increase. Application of steel stress increase is not permitted.

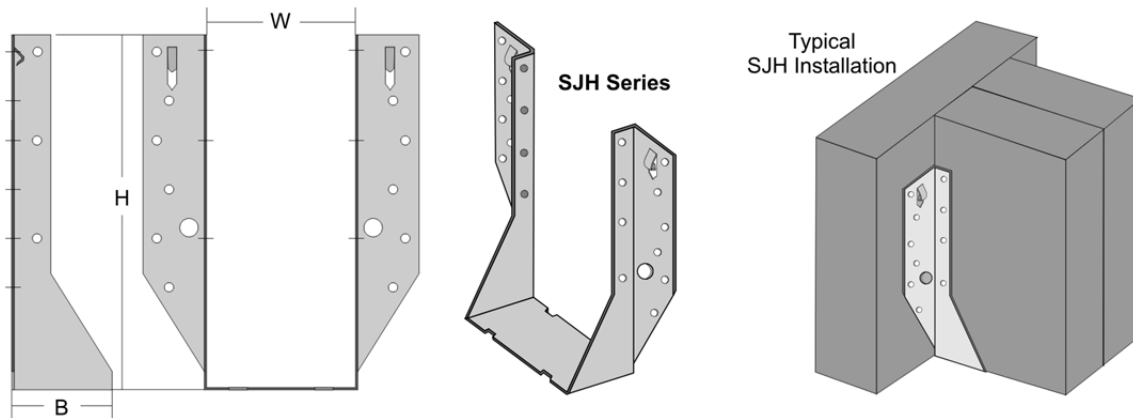

FIGURE 2—ALUS & AU SERIES

TABLE 3—RAFTER TIE RT AND HT SERIES ALLOWABLE LOADS (Pounds)⁵

Model	Connection Achieved	Steel Gauge	H (in)	Nail schedule ¹			Allowable Uplift Loads ⁴ (lbs)	
				To Rafters	To Plates	To Studs	DFL ²	SYP ³
RT1	Rafter to single plate	18	4 ³ / ₈	4-10d	4-10d	-	-	341
RT2L RT2R	Rafter to dbl, plate/top plates To stud/stud to sill plate	18	5 ³ / ₈	5-8d	5-8d	-	497	497
RT2A	Rafter to dbl, plate/top plates To stud/stud to sill plate	18	6	5-10d	5-10d	-	765	765
RT9	Rafter to stud (alignment required)	18	9 ⁷ / ₁₆	5-8d	2-8d	5-8d	-	355
RT15	Rafter to dbl plate for high wind	18	5 ¹ / ₄	4-10d	4-10d	-	493	493
RT16	Rafter to dbl plate for high wind	18	6 ¹ / ₄	8-10d	8-10d	-	1472	1587
HT8	Rafter or stud to dbl plates for high wind	18	8	5-10d	5-10d	5-10d	784	784
	Stud to single plate	18	8	-	3-10d	5-10d	375	375
HT12	Rafter to stud	18	12	7-10d	7-10d	-	1027	1027

For SI: 1 inch = 25.4 mm, 1 lbf = 4.5 N.

¹Nails are 8d or 10d common wire nails or 1¹/₂ inch joist hanger nails complying with Section 3.8.3.

²Allowable loads are for hangers nailed into wood or structural composite lumber having an effective specific gravity of 0.50 (such as Douglas Fir-Larch) or greater.

³Allowable loads are for hangers nailed into wood or structural composite lumber having an effective specific gravity of 0.55 (such as Southern Pine) or greater.

⁴Allowable uplift loads have been adjusted by a load duration factor C_D, of 1.6 (160%), corresponding to the typical duration of wind and earthquake loads. No further increases in allowable loads are permitted.

⁵Tabulated loads are without a 33% steel stress increase. Application of steel stress increase is not permitted.

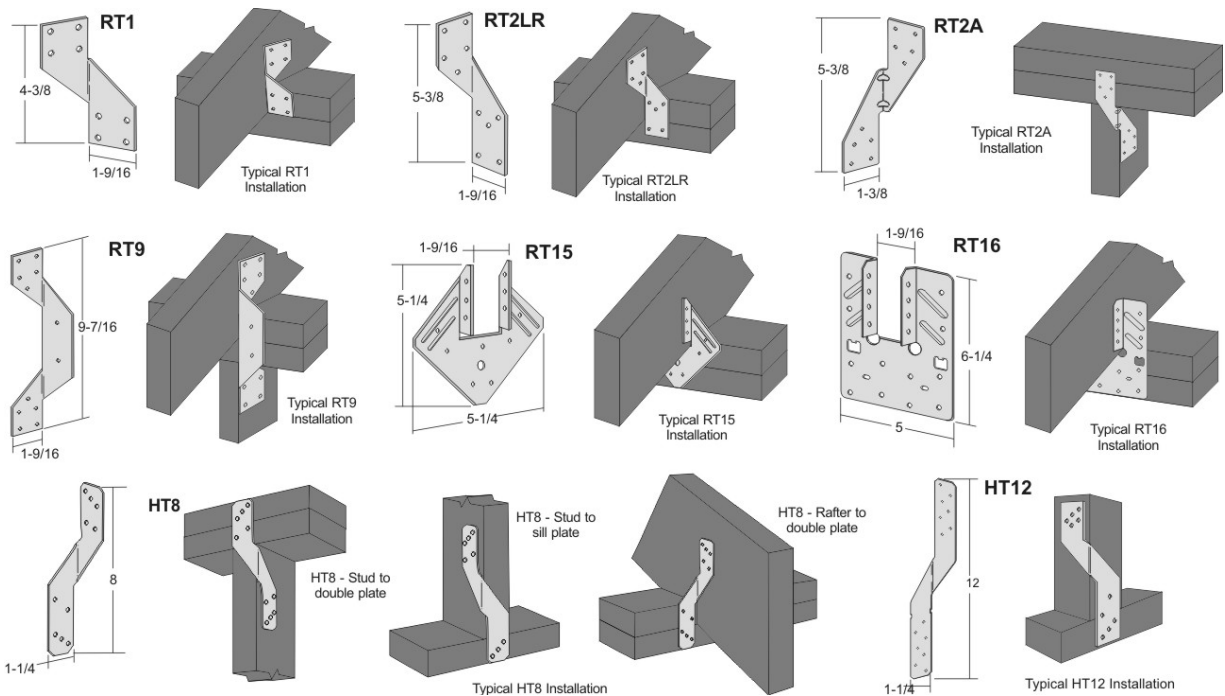

FIGURE 3—RT AND HT SERIES

TABLE 4—TRUSS HANGER TH AND DTH SERIES ALLOWABLE LOADS (POUNDS)⁵

MODEL	DIMENSIONS (INCHES)			STEEL GAGE NO.	NAIL SCHEDULE ¹		ALLOWABLE LOADS – SYP ² (LBS)			
	H	W	B		Joist	Header	Uplift ³ 160%	Gravity ⁴ 100%	Gravity ⁴ 115%	Gravity ⁴ 125%
TH18	18 ³ / ₄	1 ⁵ / ₈	3 ¹ / ₂	18	8	14	1221	1736	1996	2000
DTH18	18 ³ / ₄	3 ¹ / ₂	3 ¹ / ₂	18	8	16	1221	1984	2282	2333

For SI: 1 inch = 25.4 mm, 1 lbf = 4.5 N.

¹Nails are 10d by 1½ inch joist hanger nails complying with Section 3.8.3.

²Allowable loads are for hangers nailed into wood or structural composite lumber having an effective specific gravity of 0.55 (such as Southern Pine) or greater.

³Allowable uplift loads have been adjusted by a load duration factor C_D, of 1.6 (160%), corresponding to the typical duration of wind and earthquake loads. No further increases in allowable loads are permitted.

⁴Allowable gravity (bearing) loads have been adjusted by load duration factors, C_D, of 1.0 (100%), 1.15 (115%), and 1.25 (125%), corresponding to the typical durations of occupancy live loads, snow loads and construction loads, respectively. No further increases in allowable loads are permitted.

⁵Tabulated loads are without a 33% steel stress increase. Application of steel stress increase is not permitted.

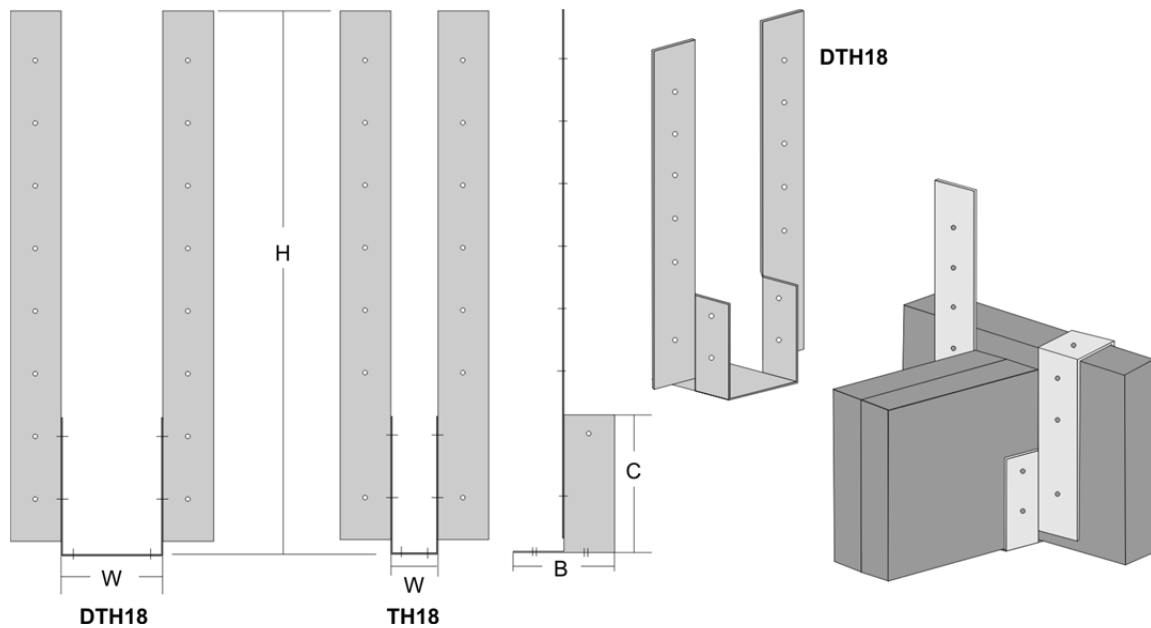

FIGURE 4—TH AND DTH SERIES

TABLE 5—FLAT WALL BRACE WB AND WBT SERIES INSTALLATION^{1,2}

Model	Length	Steel Gauge No.	Width	Angle / Wall Height	Nail Schedule ¹	
					Plate	Stud
WB10 ³	9'3"	16	1¼	60° / 8 feet	3-10d	1-10d
WB12 ³	11'5"	16	1¼	45° / 8 feet	3-10d	1-10d
WB14 ³	13'6"	16	1¼	45° / 10 feet	3-10d	1-10d
WB16 ³	15'6"	16	1¼	45° / 12 feet	3-10d	1-10d
WBT10	9'6"	22	2	60° / 8 feet	4-8d	1-8d
WBT12	11'4"	22	2	45° / 8 feet	4-8d	1-8d

For SI: 1 inch = 25.4 mm.

¹Nails are 10d by 1½ inch joist hanger nails complying with Section 3.8.3.

²Wall studs and plates must have an equivalent specific gravity of 0.55 (such as Southern Pine) or greater.

³WB wall bracing must be installed in pairs, sloped in opposite directions.

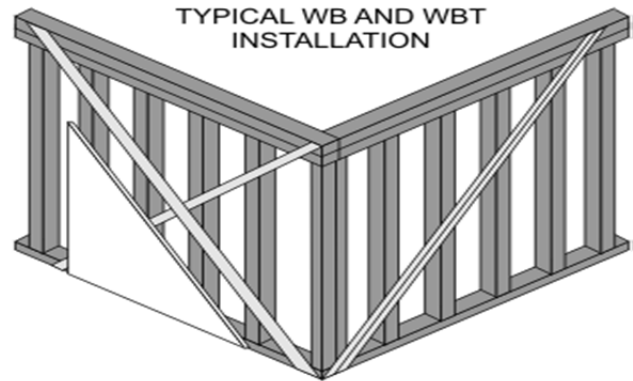
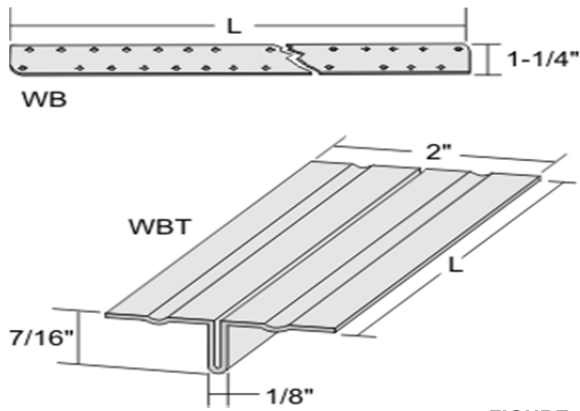

FIGURE 5—WB AND WBT SERIES

TABLE 6—HURRICANE STRAP SS, MSS AND HSS SERIES

MODEL	STEEL YIELD AND TENSILE STRENGTHS (ksi)	STEEL GAGE NO.	DIMENSIONS (inches)	10d NAILS ¹ (Quantity Each End)
SS9	F _y = 33 ksi; F _u = 45 ksi	20	1 1/4 x 10	3, 4
SS9HS	F _y = 48 ksi; F _u = 58 ksi			
MSS9	F _y = 33 ksi; F _u = 45 ksi	18		
MSS9HS	F _y = 48 ksi; F _u = 58 ksi			
HSS9	F _y = 33 ksi; F _u = 45 ksi	16		
HSS9HS	F _y = 48 ksi; F _u = 58 ksi			
SS12	F _y = 33 ksi; F _u = 45 ksi	20	1 1/4 x 12	3, 4, 5
SS12HS	F _y = 48 ksi; F _u = 58 ksi			
MSS12	F _y = 33 ksi; F _u = 45 ksi	18		
MSS12HS	F _y = 48 ksi; F _u = 58 ksi			
HSS12	F _y = 33 ksi; F _u = 45 ksi	16		
HSS12HS	F _y = 48 ksi; F _u = 58 ksi			
SS18	F _y = 33 ksi; F _u = 45 ksi	20	1 1/4 x 18	3, 4, 5, 6, 7, 8
SS18HS	F _y = 48 ksi; F _u = 58 ksi			
MSS18	F _y = 33 ksi; F _u = 45 ksi	18		
MSS18HS	F _y = 48 ksi; F _u = 58 ksi			
HSS18	F _y = 33 ksi; F _u = 45 ksi	16		
HSS18HS	F _y = 48 ksi; F _u = 58 ksi			
SS24	F _y = 33 ksi; F _u = 45 ksi	20	1 1/4 x 24	5, 6, 7, 8, 9, 10, 11
SS24HS	F _y = 48 ksi; F _u = 58 ksi			
MSS24	F _y = 33 ksi; F _u = 45 ksi	18		
MSS24HS	F _y = 48 ksi; F _u = 58 ksi			
HSS24	F _y = 33 ksi; F _u = 45 ksi	16		
HSS24HS	F _y = 48 ksi; F _u = 58 ksi			
SS30	F _y = 33 ksi; F _u = 45 ksi	20	1 1/4 x 30	7, 8, 9, 10, 11
SS30HS	F _y = 48 ksi; F _u = 58 ksi			
MSS30	F _y = 33 ksi; F _u = 45 ksi	18		
MSS30HS	F _y = 48 ksi; F _u = 58 ksi			
HSS30	F _y = 33 ksi; F _u = 45 ksi	16		
HSS30HS	F _y = 48 ksi; F _u = 58 ksi			
SS36	F _y = 33 ksi; F _u = 45 ksi	20	1 1/4 x 36	8, 9, 10, 11, 12, 14
SS36HS	F _y = 48 ksi; F _u = 58 ksi			
MSS36	F _y = 33 ksi; F _u = 45 ksi	18		
MSS36HS	F _y = 48 ksi; F _u = 58 ksi			
HSS36	F _y = 33 ksi; F _u = 45 ksi	16		
HSS36HS	F _y = 48 ksi; F _u = 58 ksi			

TABLE 6—HURRICANE STRAP SS, MSS AND HSS SERIES (Continued)

Qty. of 10d nails at each end ¹	Allowable Tension Loads (lbs) 20 Ga Steel ^{2,3,4,5}						Allowable Tension Loads (lbs) 18 Ga Steel ^{2,3,4,5}						Allowable Tension Loads (lbs) 16 Ga Steel ^{2,3,4,5}					
	A653, FY=48, FU=58 Ksi			A653, FY=33, FU=45 Ksi			A653, FY=48, FU=58 Ksi			A653, FY=33, FU=45 Ksi			A653, FY=48, FU=58 Ksi			A653, FY=33, FU=45 Ksi		
	SYP	DFL	SPF/HF	SYP	DFL	SPF/HF	SYP	DFL	SPF/HF	SYP	DFL	SPF/HF	SYP	DFL	SPF/HF	SYP	DFL	SPF/HF
3	590	547	470	590	547	470	595	552	475	595	552	475	605	557	480	605	557	480
4	787	730	627	787	730	627	794	736	634	794	736	634	806	742	640	806	742	640
5	984	912	784	873	873	784	992	920	792	992	920	792	1008	928	800	1008	928	800
6	1125	1094	941	873	873	873	1190	1104	950	1164	1104	950	1210	1114	960	1210	1114	960
7	1125	1125	1098	873	873	873	1389	1288	1109	1164	1164	1109	1411	1299	1120	1411	1299	1120
8	1125	1125	1125	873	873	873	1500	1472	1267	1164	1164	1164	1613	1485	1280	1455	1455	1280
9	1125	1125	1125	873	873	873	1500	1500	1426	1164	1164	1164	1814	1670	1440	1455	1455	1440
10	1125	1125	1125	873	873	873	1500	1500	1500	1164	1164	1164	1875	1856	1600	1455	1455	1455
11	1125	1125	1125	873	873	873	1500	1500	1500	1164	1164	1164	1875	1875	1760	1455	1455	1455
12	1125	1125	1125	873	873	873	1500	1500	1500	1164	1164	1164	1875	1875	1875	1455	1455	1455
13	1125	1125	1125	873	873	873	1500	1500	1500	1164	1164	1164	1875	1875	1875	1455	1455	1455
14	1125	1125	1125	873	873	873	1500	1500	1500	1164	1164	1164	1875	1875	1875	1455	1455	1455

For SI: 1 inch = 25.4 mm, 1 lbf = 4.5 N.

Base-metal thicknesses are 20 gage (0.036 in.), 18 gage (0.048 in.) and 16 gage (0.062 in.)

¹Nails are 10d by 3 inch common nails complying with Section 3.8.3. Allowable tension loads are based on conditions with an equal number of nails on either side of the connection. In cases where this condition is not met, allowable tension loads must be based on the side of the connection having the fewest nails.

²Allowable tension loads include load duration factor of 1.6 per section 2.3.2 of NDS. No further increases in allowable loads are permitted.

³Allowable tension loads are based on Southern Pine (SYP) with a specific gravity of 0.55, Douglas Fir-Larch (DFL) with specific gravity 0.50, and Spruce-Pine-Fir (SPF) or Hem-Fir (HF) with specific gravity of 0.42.

⁴Tabulated loads are for ASTM A653 Steel with Fy = 33 ksi and Fu = 45 ksi or Fy=48 ksi and Fu=58 ksi.

⁵Tabulated loads are without a 33% steel stress increase. Application of steel stress increase is not permitted.

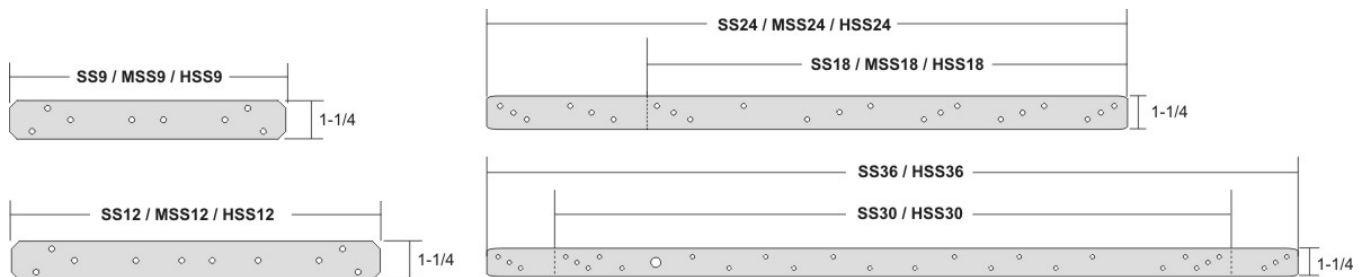

FIGURE 6—SS SERIES

TABLE 7—20 GA NAIL PLATE TNP SERIES ALLOWABLE TENSION LOADS (Pounds)^{4,5,6}

MODEL	DIMENSIONS (INCHES)	STEEL GAGE NO.	NAIL SCHEDULE ¹ (Quantity Each Side of Joint)	TENSION PARALLEL TO SHORT DIMENSION							
				DFL ²				SYP ³			
				100%	115%	125%	160%	100%	115%	125%	160%
TNP35	3x5	20	10-10d	1140	1311	1425	1824	1230	1415	1538	1968
TNP37	3x7	20	14-10d	1596	1835	1995	2554	1722	1980	2152	2755
TNP39	3x9	20	18-10d	2052	2360	2565	3283	2214	2546	2768	3542

MODEL	DIMENSIONS (INCHES)	STEEL GAGE NO.	NAIL SCHEDULE ¹ (Quantity Each Side of Joint)	TENSION PARALLEL TO LONG DIMENSION							
				DFL ²				SYP ³			
				100%	115%	125%	160%	100%	115%	125%	160%
TNP35	3x5	20	10-10d	1140	1311	1425	1824	1230	1415	1538	1831
TNP37	3x7	20	14-10d	1596	1831	1831	1831	1722	1831	1831	1831
TNP39	3x9	20	18-10d	1831	1831	1831	1831	1831	1831	1831	1831

For SI: 1 inch = 25.4 mm, 1 lbf = 4.5 N.

¹Nails are 10d by 1 1/2 inch common nails complying with Section 3.8.3.

²Allowable loads are for hangers nailed into wood or structural composite lumber having an effective specific gravity of 0.50 (such as Douglas Fir-Larch) or greater.

³Allowable loads are for hangers nailed into wood or structural composite lumber having an effective specific gravity of 0.55 (such as Southern Pine) or greater.

⁴Allowable tension loads have been adjusted by a load duration factor C_D, of 1.6 (160%), corresponding to the typical duration of wind and earthquake loads. No further increases in allowable loads are permitted.

⁵Allowable tension loads have been adjusted by load duration factors, C_D, of 1.0 (100%), 1.15 (115%), and 1.25 (125%), corresponding to the typical durations of occupancy live loads, snow loads and construction loads, respectively. No further increases in allowable loads are permitted.

⁶Tabulated loads are without a 33% steel stress increase. Application of steel stress increase is not permitted.

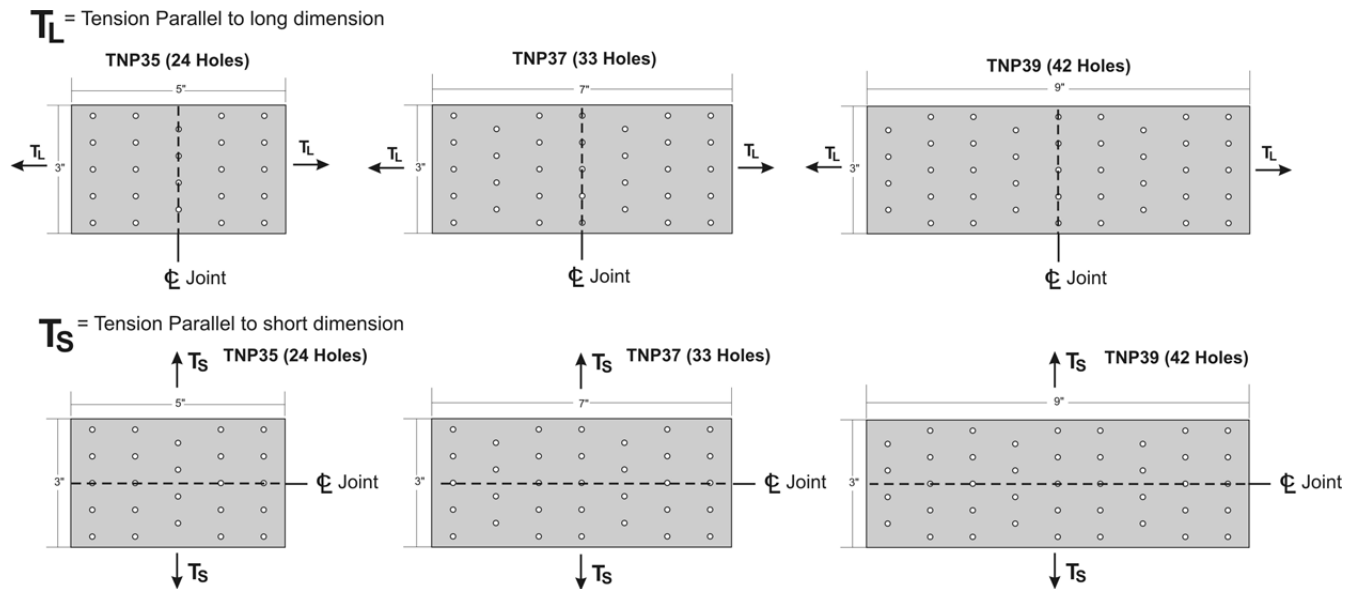

FIGURE 7—TNP SERIES

TABLE 8—CS SERIES COIL STRAPS

MODEL	STEEL GAGE NO.	TOTAL LENGTH (FEET)	WIDTH (INCHES)	END LENGTH (INCHES)	CUT TO LENGTH	FASTENERS ² (EACH END LENGTH)	ALLOWABLE TENSION LOADS ^{3,4,5,6}		
							SYP	DFL	SPF/HF
CS150	16	150	1 1/4	14	CLEAR SPAN + 28"	13 - 8d x 1 1/2	1,336	1,336	1,336
				11	CLEAR SPAN + 22"	12 - 8d x 1 1/2	1,336	1,336	1,336
CS200	18	200	1 1/4	9 1/2	CLEAR SPAN + 19"	10 - 8d x 1 1/2	1,069	1,069	1,069
				9	CLEAR SPAN + 18"	9 - 8d x 1 1/2	1,069	1,069	1,069
CS250	20	250	1 1/4	7 1/2	CLEAR SPAN + 15"	8 - 8d x 1 1/2	801	801	801
				7	CLEAR SPAN + 14"	7 - 8d x 1 1/2	801	801	801
CS300	22	300	1 1/4	7	CLEAR SPAN + 14"	7 - 8d x 1 1/2	668	668	668
				5 1/2	CLEAR SPAN + 11"	6 - 8d x 1 1/2	668	668	668

For SI: 1 inch = 25.4 mm, 1 lbf = 4.5 N.

¹Base-metal thicknesses are 22 gage (0.030 in.), 20 gage (0.036 in.), 18 gage (0.048 in.) and 16 gage (0.060 in.).

²Nails are 8d and 10d by 1 1/2 inch joist hanger nails complying with Section 3.8.3. Allowable tension loads are based on conditions with an equal number of nails on either side of the connection. In cases where this condition is not met, allowable tension loads must be based on the side of the connection having the fewest nails.

³Allowable tension loads include load duration factor of 1.6 per section 2.3.2 of NDS. No further increases in allowable loads are permitted.

⁴Allowable tension loads are based on Southern Pine (SYP) with a specific gravity of 0.55, Douglas Fir-Larch (DFL) with specific gravity 0.50, and Spruce-Pine-Fir (SPF) or Hem-Fir (HF) with specific gravity of 0.42.

⁵Tabulated loads are for ASTM A653 Steel with Fy = 33 ksi and FU = 45 ksi.

⁶Tabulated loads are without a 33% steel stress increase. Application of steel stress increase is not permitted.

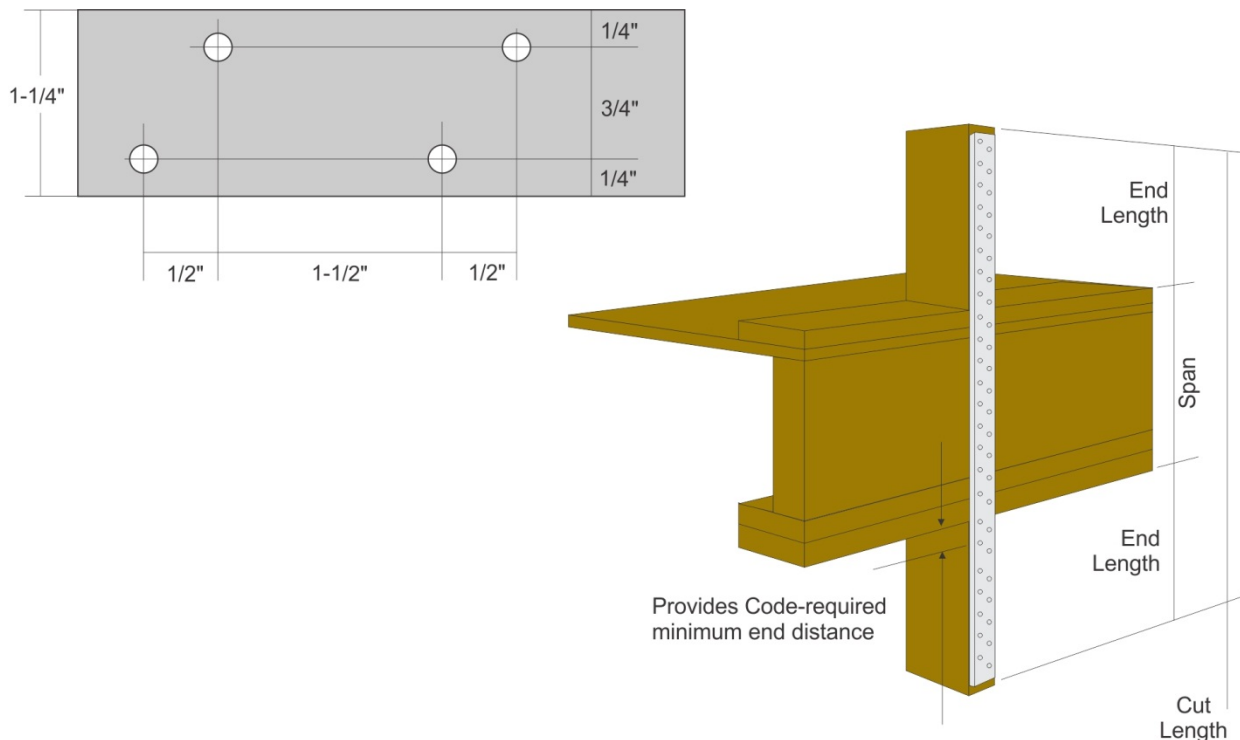

FIGURE 8—CS SERIES

TABLE 9—POST CAP ALLOWABLE LOADS (POUNDS)⁵

MODEL	DIMENSIONS (INCHES)			STEEL GAGE NO.	NAIL SCHEDULE ^{1,4}		ALLOWABLE LOADS – DFL ² (LBS)		
	H	W	B		BEAM ⁴	POST ⁴	UPLIFT ³	LATERAL H1 ³	LATERAL H2 ³
TLCE4	5 ³ / ₈	5 ³ / ₈	1 ¹ / ₄	20	14	10	2180	2188	1180

For SI: 1 inch = 25.4 mm, 1 lbf = 4.5 N.

¹Nails are 16d by 3¹/₂ inch common nails complying with Section 3.8.3.

²Allowable loads are for hangers nailed into wood or structural composite lumber having an effective specific gravity of 0.50 (such as Douglas Fir Larch) or greater.

³Allowable loads have been adjusted by a load duration factor C_D, of 1.6 (160%), corresponding to the typical duration of wind and earthquake loads. No further increases in allowable loads are permitted.

⁴Loads apply only when used in pairs, 7-16d nails in beam and 5-16d nails in post for one connector each side of beam & post

⁵Tabulated loads are without 33% steel stress increase. Application of steel stress increase is not permitted.

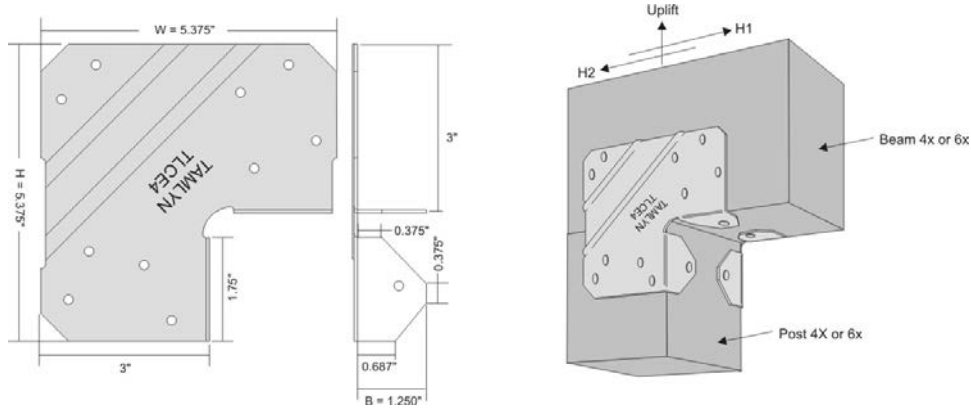

FIGURE 9—TLCE4

TABLE 10—STUD PLATE TIE ALLOWABLE LOADS (POUNDS)⁵

MODEL	CONNECTION ACHIEVED	STEEL GAGE NO.	HEIGHT (INCHES)	WIDTH (INCHES)	NAIL SCHEDULE ¹		ALLOWABLE UPLIFT LOADS ⁴ (LBS)	
					To Plate	To Stud	DFL ²	SYP ³
TRSPT6-2	Stud to dbl plate for high wind	18	5 ¹ / ₂	2 ³ / ₄	6-10d	8-10d	767	973
	Stud to single plate				6-10d	8-10d	463	463

For SI: 1 inch = 25.4 mm, 1 lbf = 4.5 N.

¹Nails are 10d common wire nails or 1¹/₂ inch joist hanger nails complying with Section 3.8.3.

²Allowable loads are for hangers nailed into wood or structural composite lumber having an effective specific gravity of 0.50 (such as Douglas-fir-Larch) or greater.

³Allowable loads are for hangers nailed into wood or structural composite lumber having an effective specific gravity of 0.55 (such as Southern Pine) or greater.

⁴Allowable uplift loads have been adjusted by load duration factor C_D, of 1.6 (160%), corresponding to the typical durations of wind and earthquake loads. No further increases in allowable loads are permitted.

⁵Tabulated loads are without 33% steel stress increase. Application of steel stress increase is not permitted.

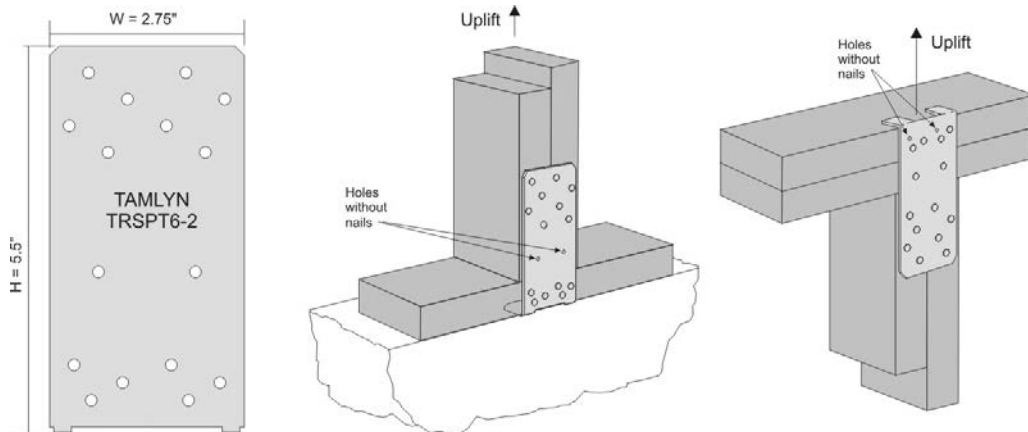

FIGURE 10—TRSPT6-2

ICC-ES Evaluation Report

ESR-1347 FBC Supplement

Reissued May 2017

This report is subject to renewal May 2019.

www.icc-es.org | (800) 423-6587 | (562) 699-0543

A Subsidiary of the International Code Council®

DIVISION: 06 00 00—WOOD, PLASTICS AND COMPOSITES
Section: 06 05 23—Wood, Plastic, and Composite Fastenings

REPORT HOLDER:

R.H. TAMLYN AND SONS, LP
13623 PIKE ROAD
STAFFORD, TEXAS 77477-5103
(281) 499-9604
www.tamlyn.com
info@tamlyn.com

EVALUATION SUBJECT:

TAMLYN AND SONS WOOD STRUCTURAL CONNECTORS

1.0 EVALUATION SCOPE

Compliance with the following codes:

- 2014 and 2010 *Florida Building Code—Building*
- 2014 and 2010 *Florida Building Code—Residential*

Property Evaluated:

Structural

2.0 PURPOSE OF THIS SUPPLEMENT

This supplement is issued to indicate that the Tamlyn and Sons Wood Structural Connectors described in Sections 2.0 through 7.0 of the master report comply with the 2014 and 2010 *Florida Building Code—Building*, and the 2014 and 2010 *Florida Building Code—Residential*, when designed and installed in accordance with the master evaluation report under the following additional conditions.

1. The connectors are selected based on the most critical load combination resulting from the load combinations noted in Section 1605.3.1 of the *Florida Building Code—Building*.
2. For use of the connectors in the High-Velocity Hurricane Zone:
 - a. The connectors are selected based on the most critical load combination resulting from the load combinations noted in Section 2.4.1 of ASCE 7.
 - b. Hangers in Table 1 to be used in the High-Velocity Hurricane Zone must have an allowable uplift capacity that exceeds the code-prescribed minimum of 700 pounds (3114 N).
 - c. Ties having an assigned allowable uplift capacity of less than 700 pounds (3114 N), in Table 3, shall be used such that two or more of the ties are installed so that the total allowable uplift capacity exceeds the code-prescribed minimum of 700 pounds (3114 N).
 - d. The number of nails chosen in accordance with Table 6 and Table 8 must be such that the allowable tension capacity exceeds the code-prescribed minimum of 700 pounds (3114 N).
 - e. Nails must be galvanized.

For products falling under Florida Rule 9N-3, verification that the report holder's quality assurance program is audited by a quality assurance entity approved by the Florida Building Commission for the type of inspections being conducted is the responsibility of an approved validation entity (or the code official when the report holder does not possess an approval by the Commission).

This supplement expires concurrently with the master report, reissued May 2019.